

# SR5719

## COMPACT ROUGH TERRAIN TELEHANDLER



- Full-time 4-wheel drive
- Fully enclosed cab
- Power assisted steering
- Proportional joystick controls
- Simple to operate & maintain

 **snorkel**<sup>™</sup>  
[www.snorkellifts.com](http://www.snorkellifts.com)

# COMPACT ROUGH TERRAIN TELEHANDLER

# SR5719

CAPABILITIES	SR5719
Max. lift capacity	2,600kg
Max. lift height (A)	5.79m
Max. forward reach	3.1m

DIMENSIONS	
Overall width (B)	1.89m
Stowed height (C)	1.93m
Length to fork face (D)*	4.19m
Wheelbase	2.5m
Ground clearance	220mm

PERFORMANCE	
Max. drive speed	27km/h
Raise/lower time	6.9/5 sec
Hydraulic flow (per minute)	70L
Hydraulic pressure	230bar
Hydraulic oil capacity	70L
Fuel capacity	80L
Outside turning radius	3.25m
Tires	12 x 16.5

POWER	
Power source	Yanmar 52kW Tier 4 Final diesel

WEIGHT	
Weight	4,700kg

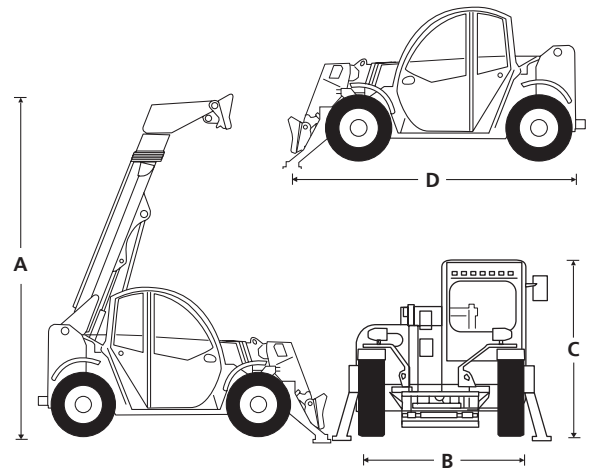

## STANDARD FEATURES

- Full-time 4-wheel drive
- 4-wheel steer
- Selectable front, crab & coordinated steering modes
- Auxillary hydraulic circuit on the boom
- Variable speed hydrostatic drive
- Proportional joystick
- Easy to access components for servicing
- Constant Flow
- Illuminated gauge and switch panels
- Colour LCD display with machine & engine diagnostics
- Block heater
- Flashing beacon
- LED road lights (4)
- LED work lights on boom (2)
- Adjustable suspension seat
- 2 year parts & labor, 5 year structural warranty
- ANSI compliant

## OPTIONS

- Special paint colors
- Multiple options for carriages, tires and fork tines
- Cold weather synthetic oil
- Swivel hook
- Hydraulic tank heater
- Universal skidsteer attachments
- Snorkel OnSite™ telematics

## LOAD CHART

